



GAI-TRONICS®  
A HUBBELL COMPANY

# RED ALERT®

## Hands-free VoIP Telephone Manual

### TABLE OF CONTENTS

*Confidentiality Notice* .....3

*Product Overview* .....3

**Features and Functions** ..... 3

**System Requirements and Limitations** ..... 4

**VoIP Subscriber Tips** ..... 5

*Operation*.....5

**Auto-dial Emergency Calls** ..... 5

**Auto-dial Non-Emergency Calls**..... 5

**General Telephone Calls** ..... 6

**Receive a Call** ..... 6

**Multicast Broadcast**..... 6

**Monitoring and Reporting** ..... 6

**Status Indication** ..... 7

        Power ..... 7

        Heartbeat..... 7

        Link ..... 7

        Speed..... 7

**VoIP Circuit PCBA Pushbuttons** ..... 7

        Reset..... 7

        Factory ..... 7

*Installation* ..... 8

**General Information**..... 8

        Safety Guidelines ..... 8

        Station Placement..... 8

        Security Hardware ..... 8

**Conduit Installation Details (Surface-Mount Models)** ..... 9

**Models 393-710, 393AL-710, and 394AL-712 (Surface Mount Applications)**..... 10

**Models 397-71x and 398-71x (Stanchion/Flush-Mount Applications)** ..... 13

**Models 397-71xFS and 398-711FS (Flush-Mount Applications)** ..... 16

**Field Wiring**..... 18

        Recommended Cabling ..... 18

        Power ..... 19

Network.....	19
I/O .....	19
USB port .....	20
<b><i>Configuration</i></b> .....	<b>20</b>
<b>VoIP Telephone Input Contacts</b> .....	<b>20</b>
<b>VoIP Telephone Output Contacts</b> .....	<b>20</b>
<b>GAI-Tronics Strobe Connection</b> .....	<b>20</b>
<b><i>Programming</i></b> .....	<b>21</b>
<b>VoIP PCBA Setup</b> .....	<b>21</b>
<b>VoIP PCBA Initial Network Configuration</b> .....	<b>22</b>
<b><i>Maintenance</i></b> .....	<b>22</b>
<b>USB port</b> .....	<b>22</b>
<b>Corrective Actions</b> .....	<b>22</b>
<b>Preventive Maintenance for Models 397-71x, 397-71xFS, 398-71x, and 398-711FS</b> .....	<b>22</b>
Cleaning .....	22
Prevention .....	23
<b>Troubleshooting</b> .....	<b>23</b>
<b>Service</b> .....	<b>23</b>
<b>Replacement and Optional Parts</b> .....	<b>24</b>
<b><i>Reference Documentation</i></b> .....	<b>25</b>
<b><i>Specifications</i></b> .....	<b>25</b>
<b>Electrical</b> .....	<b>25</b>
<b>Mechanical</b> .....	<b>25</b>
<b><i>Approvals</i></b> .....	<b>26</b>



GAI-TRONICS®  
A HUBBELL COMPANY

# RED ALERT®

## Hands-free VoIP Telephone Manual

---

### Confidentiality Notice

This manual is provided solely as an installation, operation, and maintenance guide and contains sensitive business and technical information that is confidential and proprietary to GAI-Tronics. GAI-Tronics retains all intellectual property and other rights in or to the information contained herein, and such information may only be used in connection with the operation of your GAI-Tronics product or system. This manual may not be disclosed in any form, in whole or in part, directly or indirectly, to any third party.

### Product Overview

RED ALERT® Hands-free VoIP (Voice over Internet Protocol) telephones connect to a 10/100 BaseT Ethernet network. These telephones operate from PoE (Power-over-Ethernet) or an external 24 to 48-volt dc power source. VoIP telephones provide direct point-to-point communication between personnel over an existing LAN and can also be utilized for multicast broadcasts. All models have a 3R (rainproof) weatherproof rating.

RED ALERT VoIP telephones feature real-time alarm reporting. System supervisors monitor each telephone's activity and address caller needs or maintenance issues immediately. The telephones have four user-configurable inputs and two outputs for customer use.

### Features and Functions

RED ALERT VoIP (Voice-over-Internet Protocol) hands-free telephones include the following features:

- SIP compatible (RFC3261)
- automatic call diversion (memory list)
- weather and vandal-resistant
- real-time alarm reporting via SNMP, syslog, or TMA software
- PoE (Power over Ethernet) compatible
- configurable via web page, serial link, or download
- four auxiliary inputs, two dry-contact outputs
- multicast capability, up to eight addresses
- ADA (Americans with Disabilities Act) compliant

Table 1 lists the RED ALERT VoIP telephones detailed in this manual:

Table 1. Model Chart

<b>Model</b>	<b>Description</b>
<b>393-710</b>	<b>Surface-Mount VoIP Telephone</b> , weatherproof, yellow engineered plastic enclosure, HELP auto-dial push button, and CALL RECEIVED WHEN LIT LED.
<b>393AL-710</b>	<b>Surface-Mount VoIP Telephone</b> , weatherproof, cast-aluminum enclosure painted safety yellow, HELP auto-dial push button, and CALL RECEIVED WHEN LIT LED.
<b>394AL-712</b>	<b>Surface-Mount VoIP Telephone</b> , weatherproof, cast-aluminum enclosure painted safety yellow, HELP auto-dial push button, CALL (off-hook) button, 12-button Braille keypad, and CALL RECEIVED WHEN LIT LED.
<b>397-710</b>	<b>Flush-Mount VoIP Telephone</b> , weatherproof, brushed stainless steel front panel, HELP auto-dial push button, and CALL RECEIVED WHEN LIT LED.
<b>397-710FS</b>	<b>Flush-Mount Compact VoIP Telephone</b> , weatherproof, brushed stainless steel front panel, HELP auto-dial push button, and CALL RECEIVED WHEN LIT LED. <b>This telephone is functionally identical to Model 397-710.</b>
<b>397-711</b>	<b>Flush-Mount VoIP Telephone</b> , weatherproof, brushed stainless steel front panel, HELP auto-dial push button, ASSISTANCE auto-dial push button, and CALL RECEIVED WHEN LIT LED.
<b>397-711FS</b>	<b>Flush-Mount Compact VoIP Telephone</b> , weatherproof, brushed stainless steel front panel, HELP auto-dial push button, ASSISTANCE auto-dial push button, and CALL RECEIVED WHEN LIT LED. <b>This telephone is functionally identical to Model 397-711.</b>
<b>398-711</b>	<b>Flush-Mount VoIP Telephone</b> , weatherproof, brushed stainless steel front panel, CALL (off-hook) push button, 12-button Braille keypad, and CALL RECEIVED WHEN LIT LED. <b>This telephone is simply a rugged, hands-free telephone, which is not intended for emergency use.</b>
<b>398-711FS</b>	<b>Flush-Mount Compact VoIP Telephone</b> , weatherproof, brushed stainless steel front panel, CALL (off-hook) push button, 12-button Braille keypad, and CALL RECEIVED WHEN LIT LED. <b>This telephone is simply a rugged, hands-free telephone, which is not intended for emergency use. This telephone is functionally identical to Model 398-711.</b>
<b>398-712</b>	<b>Flush-Mount VoIP Telephone</b> , weatherproof, brushed stainless steel front panel, HELP auto-dial push button, CALL (off-hook) button, 12-button Braille keypad, and CALL RECEIVED WHEN LIT LED.

## System Requirements and Limitations

RED ALERT VoIP telephones require PoE (Power-over-Ethernet) or a local 24 to 48-volt dc power source for operation. Two VoIP telephones can be connected in a peer-to-peer configuration without the need for a LAN. A 10/100 BaseT Ethernet network with a SIP (Session Initiation Protocol) server is required for systems containing three or more VoIP telephones. Conferences are limited by the customer's LAN media capabilities and the services available at each end point.

These telephones also receive multicast broadcasts. A multicast audio stream is sent to multiple end points simultaneously to achieve multi-point paging or public address functionality over IP. Multicast requires the use of a SIP server that specifically supports multicast functionality and each telephone must be configured (enabled) to receive multicast packets.

## VoIP Subscriber Tips

New and existing subscriptions to an interconnected VoIP service provider should address the following points:

- Provide accurate physical address information to the VoIP service provider to ensure that emergency services can quickly be dispatched to the location.
- Be familiar with the VoIP service provider's procedures for updating the address and promptly update address information in the event of a change.
- Have a clear understanding of any limitations of the local 911 service.
- Be aware that VoIP telephone services may not work if the power is out or the Internet connection is down. Consider installing a backup power supply, maintaining a traditional telephone line, or having a wireless telephone as a backup.
- For questions about interconnected VoIP and 911, or VoIP in general, see <http://www.fcc.gov/cgb/consumerfacts/voip.html>.

## Operation

### Auto-dial Emergency Calls

**Models 393-710, 393AL-710, 394AL-712, 397-710, 397-710FS, 397-711, 397-711FS, and 398-712**

To place an emergency call:

Press the **HELP** push button to immediately call the preprogrammed emergency number; typically, a security office or 911.

- The **CALL RECEIVED WHEN LIT LED** illuminates steadily in accordance with the ADA (Americans with Disabilities Act) when the call is answered.
- The call cannot be terminated by the initiator.
- The call is terminated by any of the following:
  - the receiving caller hangs up
  - the defined call-duration timeout is exceeded
  - the SIP server disconnects the call

### Auto-dial Non-Emergency Calls

**Models 397-711 and 397-711FS**

To place a non-emergency call:

Press the **ASSISTANCE** push button to immediately call the preprogrammed non-emergency number (garage, dorm, etc.).

- The **CALL RECEIVED WHEN LIT LED** illuminates steadily in accordance with the ADA (Americans with Disabilities Act) when the call is answered.
- The call is terminated by the any of the following:
  - pressing the **ASSISTANCE** push button again
  - the receiving caller hangs up

- the defined call-duration timeout is exceeded
- the SIP server disconnects the call

## General Telephone Calls

### Models 394AL-712, 398-711, 398-711FS, and 398-712

To place a general telephone call:

1. Press the CALL push button.
2. Wait for the dial tone.
3. Use the keypad to dial the desired number.
  - The CALL RECEIVED WHEN LIT LED illuminates steadily in accordance with the ADA when the call is answered.
  - The call is terminated by any of the following:
    - pressing the CALL push button again
    - the receiving caller hangs up
    - the defined call-duration timeout is exceeded
    - the SIP server disconnects the call.

## Receive a Call

RED ALERT VoIP emergency telephones automatically go off-hook (auto-answer) when called. A conversation can then take place.

## Multicast Broadcast

When making a multicast call, the SIP server sends the page request to a specific IP address and multiple telephones accept and play the subsequent audio. GAI-Tronics' VoIP telephones can be programmed for up to eight multicast addresses to permit the receipt of multicast broadcasts from different sources or to enable zoning of broadcasts. Each multicast address can be assigned a priority (via programming) to define broadcast override. A telephone with multicast enabled can still make and receive normal calls (peer-to-peer or SIP server). Normal calls can be assigned a priority level, defining whether calls can override multicasts or vice versa.

## Monitoring and Reporting

Each telephone can recognize and generate several hardware and configuration fault condition alarms. These alarms can be signaled to a remote site using three methods:

- Syslog output over TCP
- SNMP (Simple Network Management Protocol)
- TMA (Telephone Management Application) software (purchased separately)

**NOTE:** The TMA software permits *system* monitoring and data collection/reporting from a central location.

Available alarms are:

- handset integrity loop (if applicable)
- configuration error
- cold reset (power cycle)

- warm reset (internal command)
- keypad error (if applicable)
- key hook (off hook status, if applicable)
- register fail (unsuccessful SIP registration)
- audio path test (speaker/microphone test)

## Status Indication

### Power

The ON LED, located on the VoIP PCBA (see [Figure 21](#) on [Page 18](#)), illuminates when power is applied to the telephone.

### Heartbeat

The HB LED, located on the VoIP PCBA (see [Figure 21](#) on [Page 18](#)), flashes when communication over the LAN is established.

### Link

The LNK LED, located on the VoIP PCBA (see [Figure 21](#) on [Page 18](#)), indicates an active network connection when illuminated.

### Speed

The SP LED, located on the VoIP PCBA, (see [Figure 21](#) on [Page 18](#)) indicates a 100 Mbps network connection when illuminated or a 10 Mbps connection when off.

## VoIP Circuit PCBA Pushbuttons

### Reset

Press the RESET button (see [Figure 21](#) on [Page 18](#)) momentarily to warm reboot the telephone. The telephone maintains the current configuration.

### Factory



Use the FACTORY button (see [Figure 21](#) on [Page 18](#)) to erase the current configuration and restore the factory default settings as follows:



1. Press and release the RESET button.
2. Press and hold the FACTORY button for 10 seconds while the telephone is rebooting.

The telephone will reboot again with the factory default settings configured.

# Installation

## General Information

 **WARNING**  —This product can contain hazardous voltages. Always remove power to this station and any associated equipment before beginning any installation.

 **CAUTION**  —Do not install this equipment in areas other than those indicated on the approval listing in the Approvals section of this manual. Such installation may cause a safety hazard and consequent injury or property damage.

Install equipment without modification and according to all applicable local and national electrical codes. Consult the National Electrical Code (NFPA 70), Canadian Standards Association (CSA 22.1), and local codes for specific requirements regarding your installation. Class 2 circuit wiring must be performed in accordance with the NEC.

## Safety Guidelines

When installing any GAI-Tronics equipment, please adhere to the following guidelines to ensure the safety of all personnel:

- Do not install wiring during a lightning storm.
- **Electrostatic Discharge (ESD) Protection:** VoIP telephones may have an earth ground terminal provision. If so, ensure that it is connected to ground in accordance with all local safety regulations and the National Electrical Code (NEC). Grounding must be ensured for safe and stable communications. Do not use long and coiled ground wires. Trim ground wires to the required length. Use a star configuration whenever possible. Please note; proper grounding does not eliminate the need for lightning protection for the telephone or the telephone system. A category 5 data line lightning surge protector is recommended for telephones subject to any electrostatic discharge (e.g. lightning).
- Do not install jacks in wet locations unless the jack is specifically designed for wet locations.

## Station Placement

Consider station placement and volume levels to prevent feedback problems in the system. To reduce unpleasant feedback problems:

- point each telephone away from other nearby telephones
- reduce the volume levels

## Security Hardware

The telephones described in this manual are vandal resistant. The front panel of each telephone covered in this manual is attached to its enclosure with security screws. A GAI-Tronics Model 233-001 security screwdriver or Torx T-25 security head tip (sold separately) is required to install the telephone.



## Conduit Installation Details (Surface-Mount Models)

GAI-Tronics recommends installing Ethernet and power lines in conduit to protect against accidental damage and vandalism. To prevent moisture from entering the enclosure, the following is recommended:

- Conduit should enter the enclosure from the bottom.
- Sealed fittings should be installed at all cable entry points.
- Silicone sealant or equivalent should be applied around and inside all conduit entries.

Please refer to the examples below for the recommended conduit installation details.

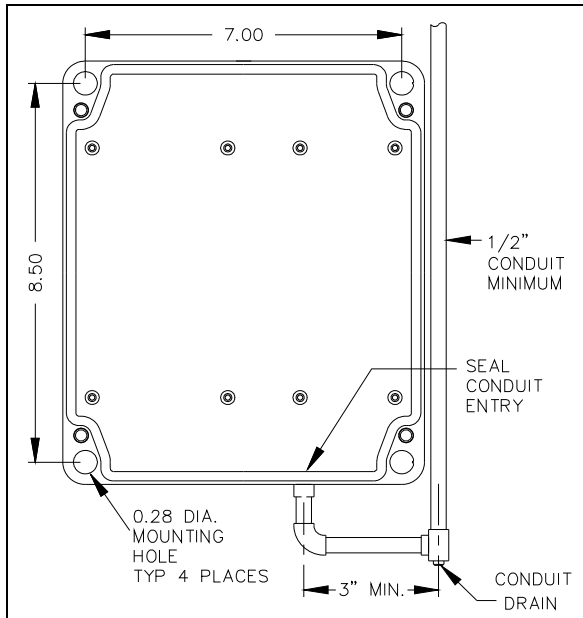

Figure 1. Bottom entry conduit recommended for non-metallic enclosures

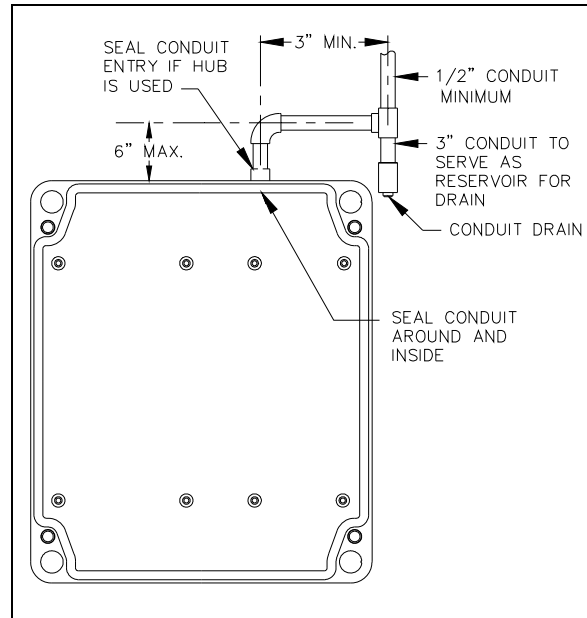

Figure 2. Top entry conduit installation for non-metallic enclosures (NOT recommended)

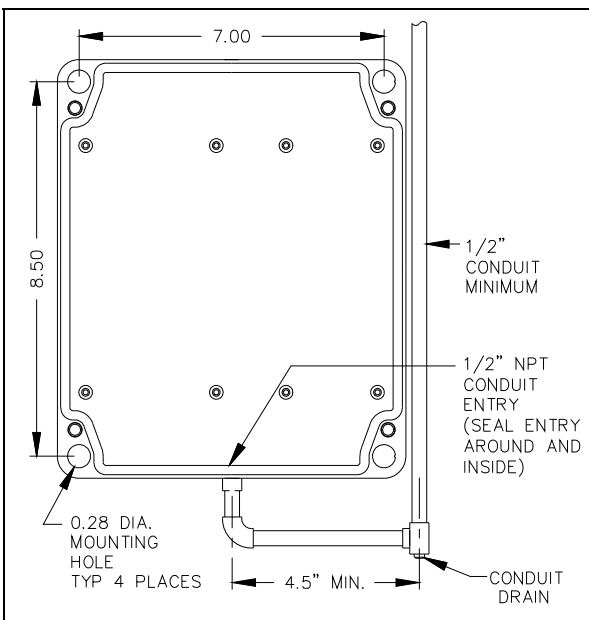

Figure 3. Bottom entry conduit installation details for metallic enclosures

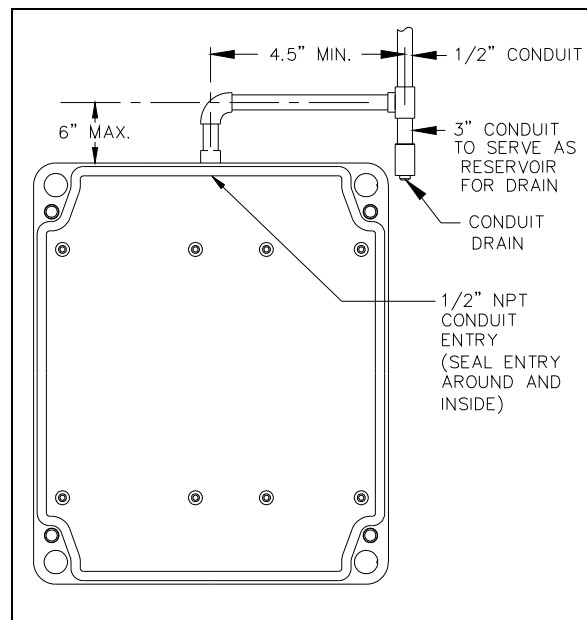

Figure 4. Top entry conduit installation details for metallic enclosures (NOT recommended)

## Models 393-710, 393AL-710, and 394AL-712 (Surface Mount Applications)

1. Remove the four security screws from the front panel.

2. Position the enclosure on the mounting surface.

The enclosure has four 0.28-inch diameter mounting holes in a 7.0 × 8.5-inch hole pattern.

3. Secure the enclosure to its mounting surface with four ¼-inch diameter bolts of the appropriate length for the surface.

**NOTE:** When using the *GAI-Tronics Model 231-001 Pole Mounting Kit*: follow the mounting instructions provided in the kit.

**NOTE:** Installation of a (customer-supplied) surge suppresser is recommended on the Ethernet cable for outdoor installations.

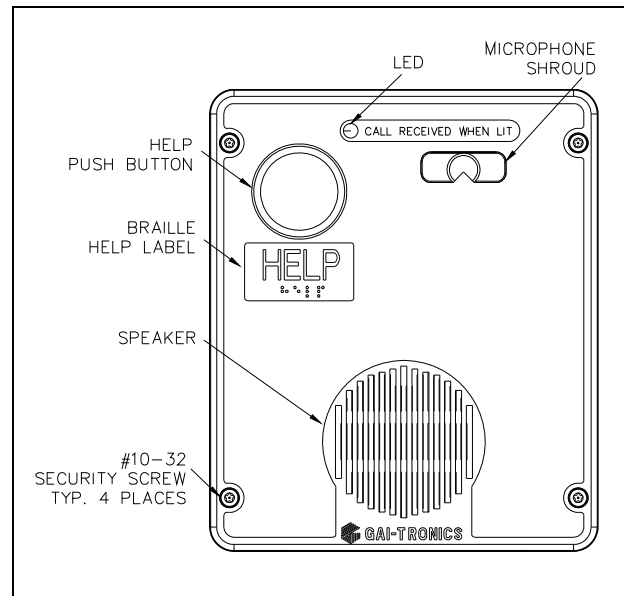

Figure 5. Model 393-710 VoIP Telephone in a Non-metallic Enclosure

4. *For Model 393-710 only:* Create a conduit access hole using a hole punch equivalent in size to the conduit diameter.
  - Bottom entry is strongly recommended.
  - Insert a conduit fitting in the access hole.
5. Install conduit as required (see the [Conduit Installation Details \(Surface-Mount Models\)](#) section on Page 9).
6. Use silicone sealant or equivalent around and inside all conduit entries.
7. Pull the Ethernet cable through the conduit and terminate the cable (see the [Field Wiring](#) section on Page 18).
8. Connect any desired peripheral devices (see the [I/O](#) section on Page 19).
9. Perform the initial programming of the telephone (see the [Programming](#) section on Page 21).
10. Verify telephone operation by calling to and from another telephone.
11. Verify operation of peripheral equipment.
12. Attach the front panel assembly to the rear enclosure using the four security screws.
13. Torque the screws to 10–12 in·lb.

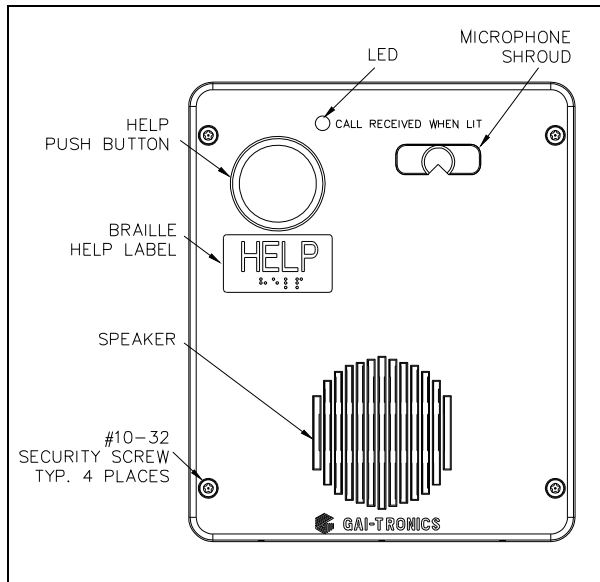

Figure 6. Model 393AL-710

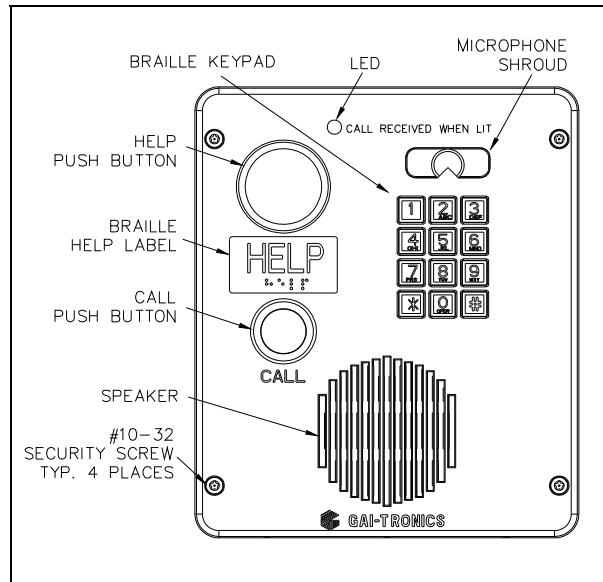

Figure 7. Model 394AL-712

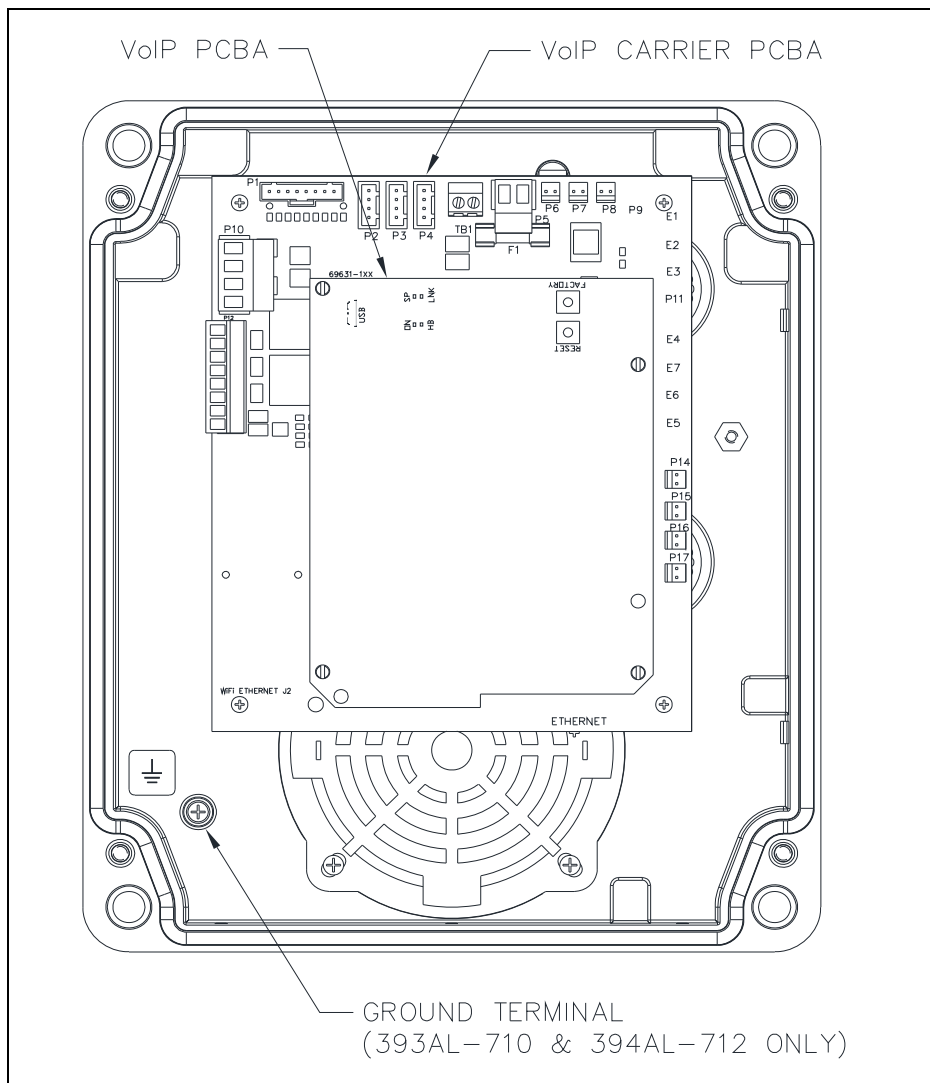

Figure 8. Component Locations for Models 393-710, 393AL-710, and 394AL-712

Models 397-71x and 398-71x (Stanchion/Flush-Mount Applications)

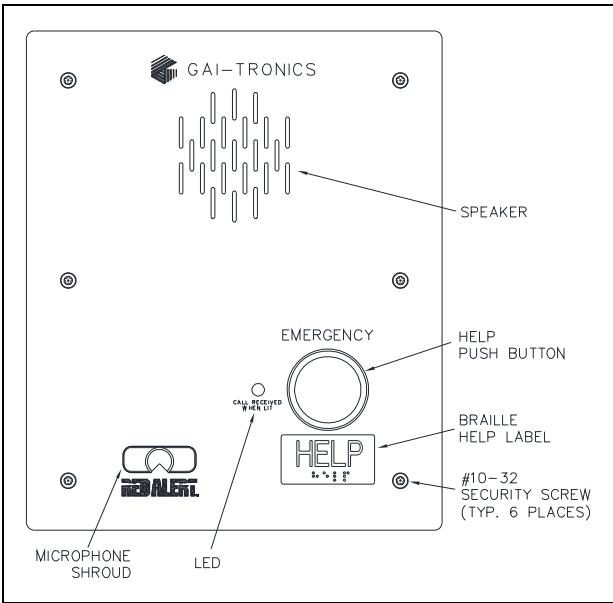

Figure 9. Model 397-710

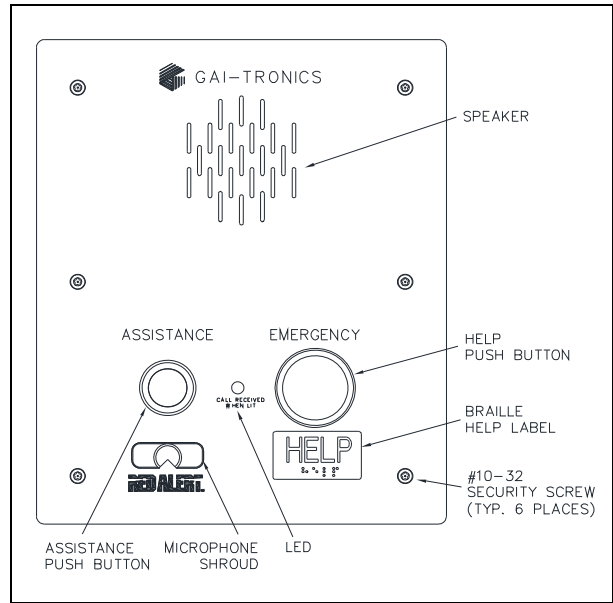

Figure 10. Model 397-711

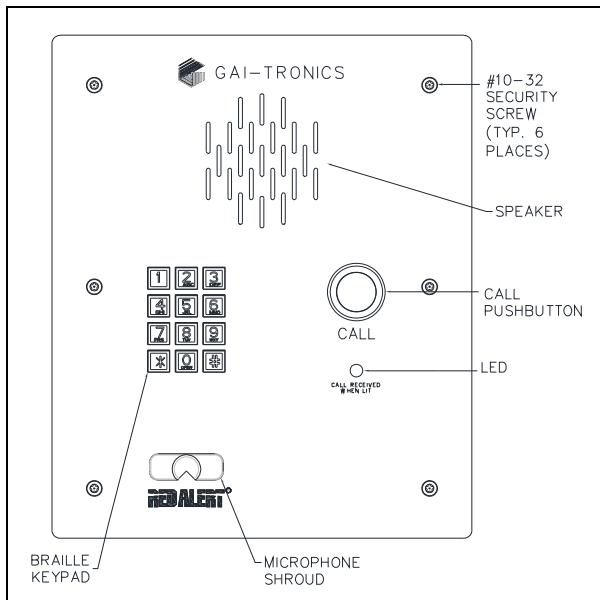

Figure 11. Model 398-711

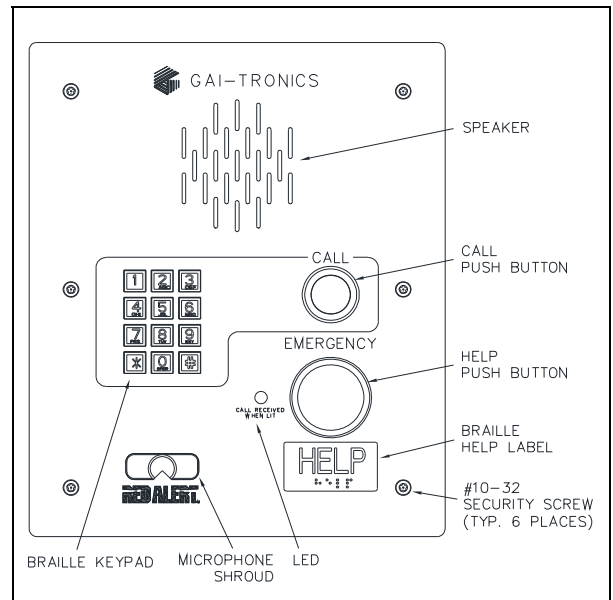

Figure 12. Model 398-712

1. Use the supplied back box to mount the Model 397-710, 397-711, 398-711 and 398-712 VoIP telephones in flush-mount applications or in a GAI-Tronics Model 234 Series communication station.
2. Mount the back box to the structure using the appropriate hardware (see Figure 15 for the cutout dimensions).

**NOTES:**

- When installing a RED ALERT flush-mount VoIP telephone in a GAI-Tronics No. 236-00x series or No. 238-001 surface-mount enclosure, the front panel assembly mounts directly to the enclosure (the back box is not required.)
- Installation of (customer-supplied) surge suppressors is recommended on the Ethernet cable and the power line (if used) for outdoor installations.

3. Remove a tapered plug from one of the cable entries in the back box.
4. Install the cable and cable fitting (see the Field Wiring section on Page 18).
5. Use silicone sealant or equivalent around and inside all conduit entries.
6. Connect any desired peripheral devices (see the I/O section on Page 19).
7. Perform the initial programming of the telephone (see the Programming section on Page 21).
8. Verify operation by calling to and from another telephone.
9. Verify operation of peripheral equipment.
10. Attach the telephone's front panel to the mounting flanges of the back box using the six supplied #10-32 security screws and washers.
11. Torque the screws to 10–12 in·lb.

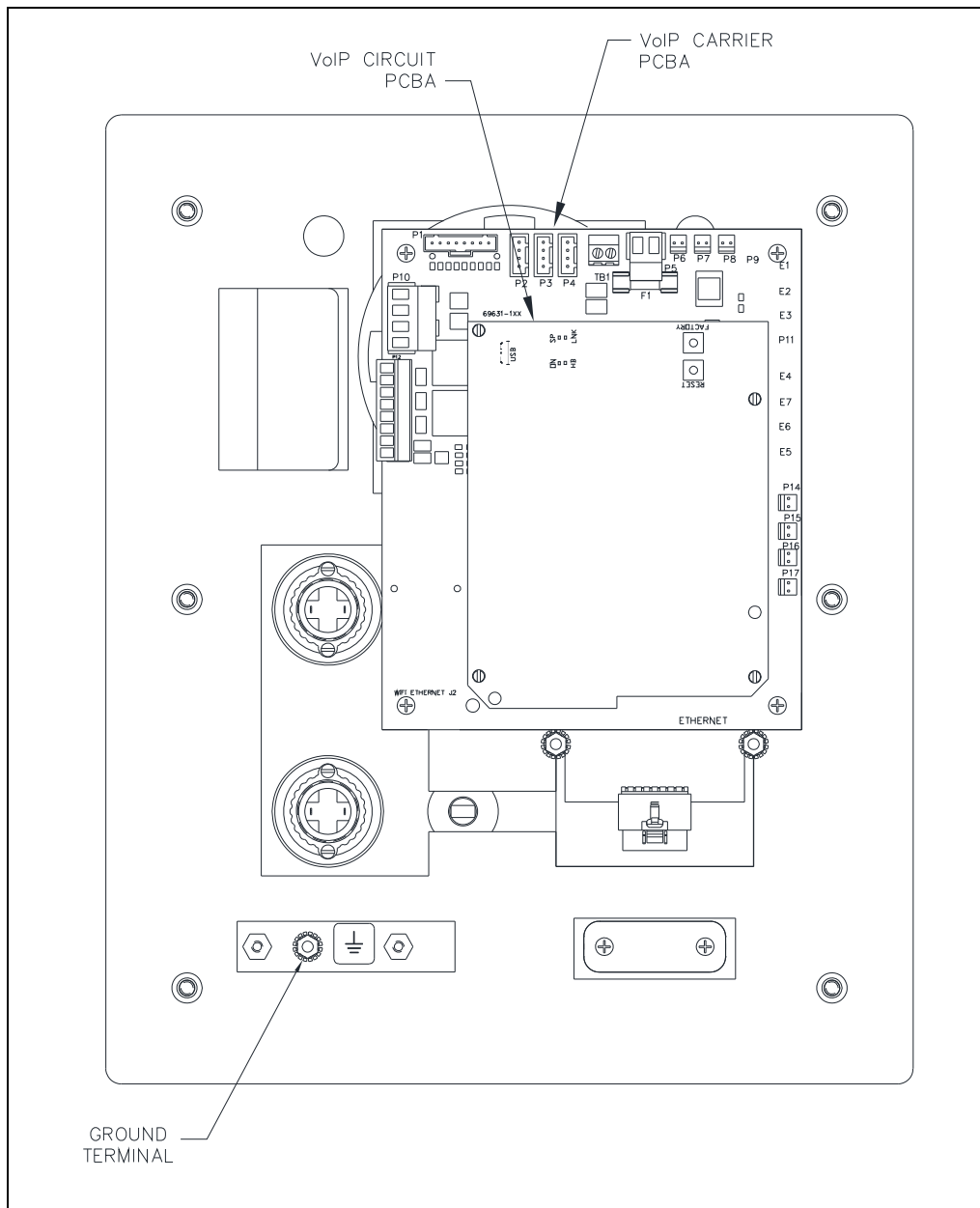

Figure 13. Component Locations for Models 397-71x and 398-71x

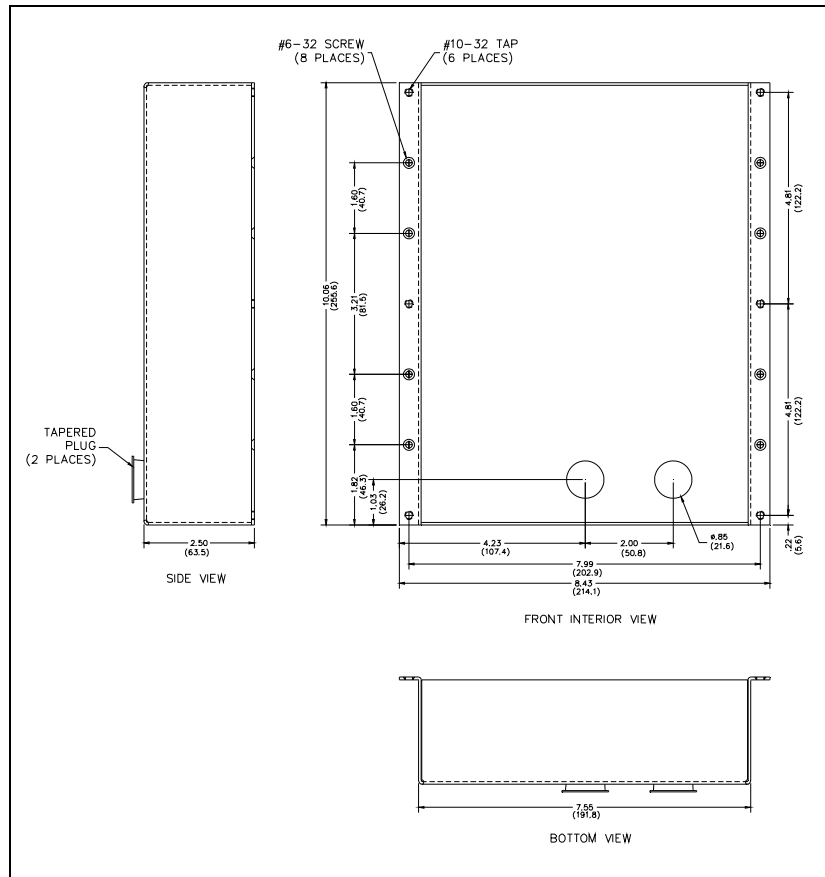

Figure 14. Flush-Mount VoIP Telephone Mounting Detail

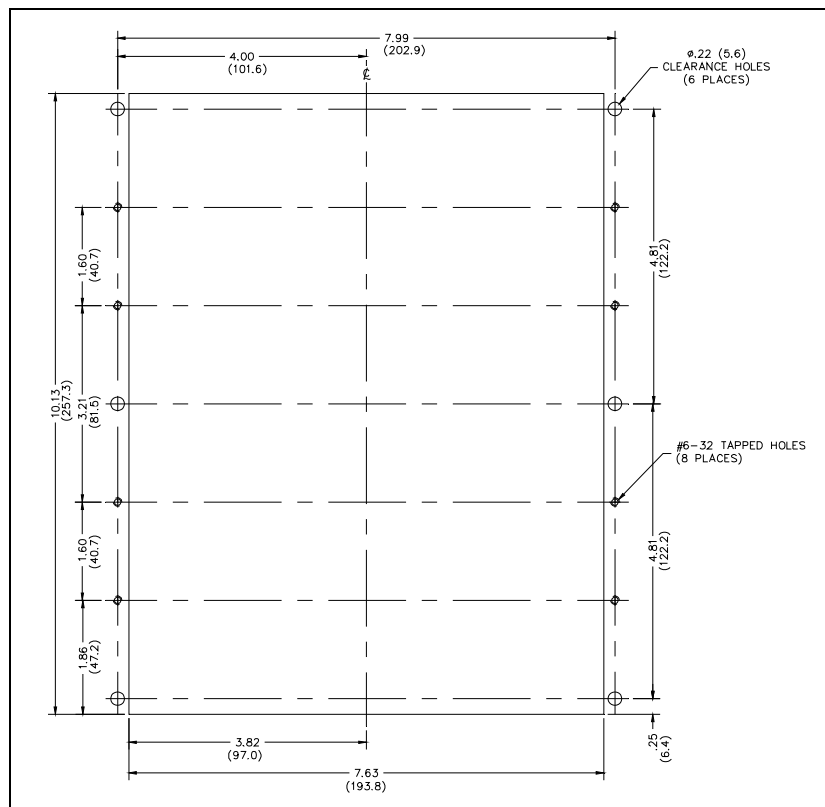

Figure 15. Cutout for Model 397-71x and 398-71x

## Models 397-71xFS and 398-711FS (Flush-Mount Applications)

Install the compact models in flush mount openings measuring 7.75 H × 5.75 W inches using a six-hole mounting pattern.

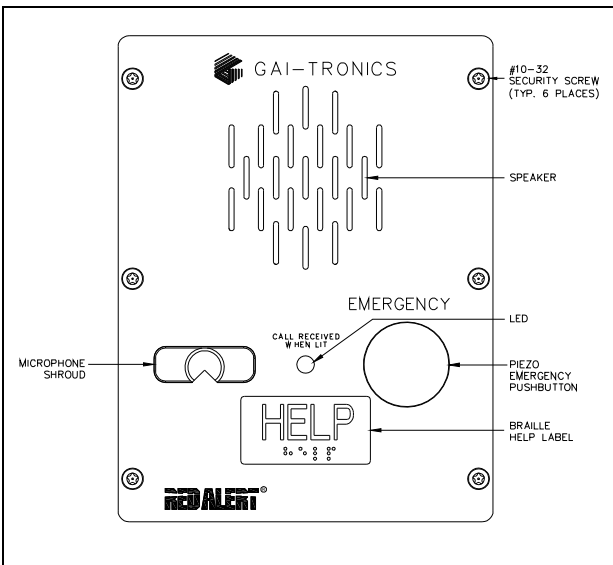

Figure 16. Model 397-710FS

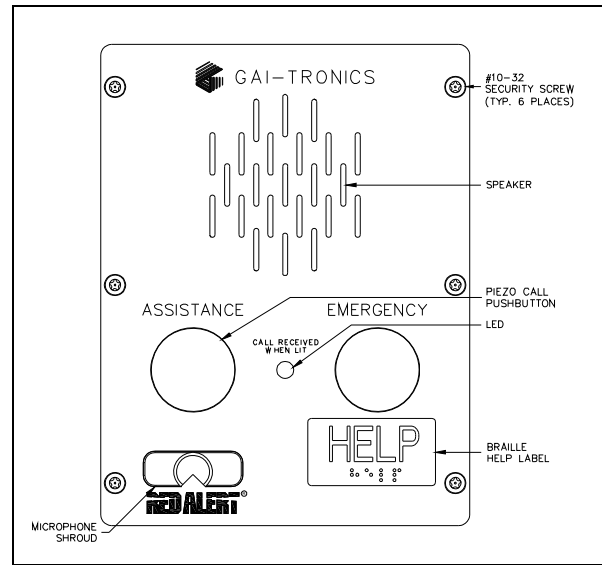

Figure 17. Model 397-711FS

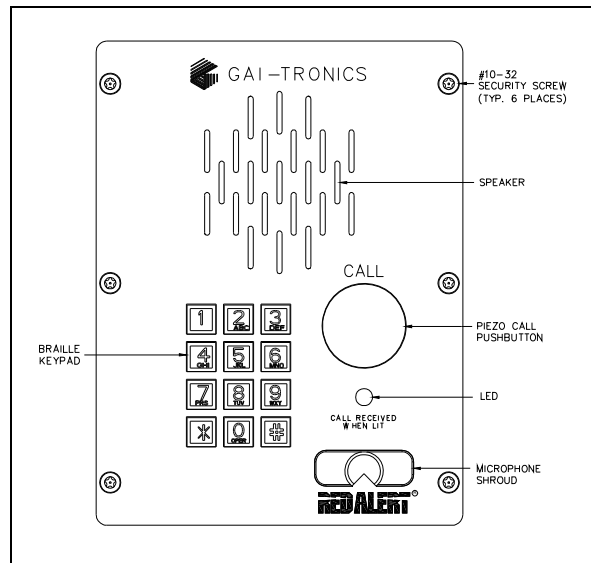

Figure 18. Model 398-711FS

1. Remove the back box from the front cover.

**NOTE:** Install a (customer-supplied) Ethernet surge suppressor in outdoor installations.

**NOTE:** Install a (customer supplied) power line surge suppressor if local power is used.

2. Remove the tapered plug(s), as necessary, from cable entry holes in the backbox.
3. Feed all cabling into the back box.
4. Connect all cables (see the [Field Wiring](#) section on Page 18).
5. Connect any desired peripheral I/O devices (see the [I/O](#) section on Page 19).



6. Re-install the back box.
7. Perform the initial programming of the telephone (see the Programming section on Page 21).
8. Verify operation by calling to and from another telephone.
9. Verify operation of peripheral equipment.
10. Attach the front panel assembly to the mounting surface using the security screws.
11. Torque the screws to 10 to 12 in·lb.

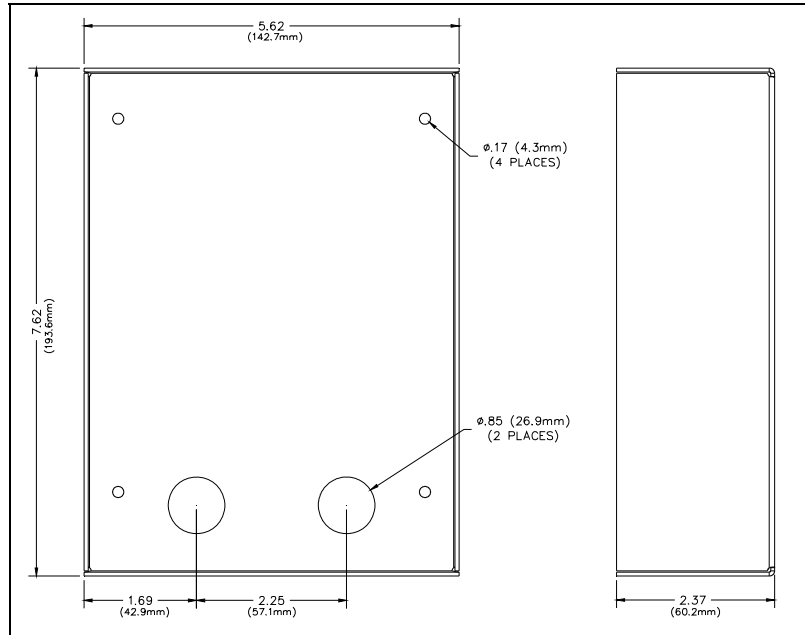

Figure 19. Model 397-710FS, 397-711FS, and 398-711FS Back Box

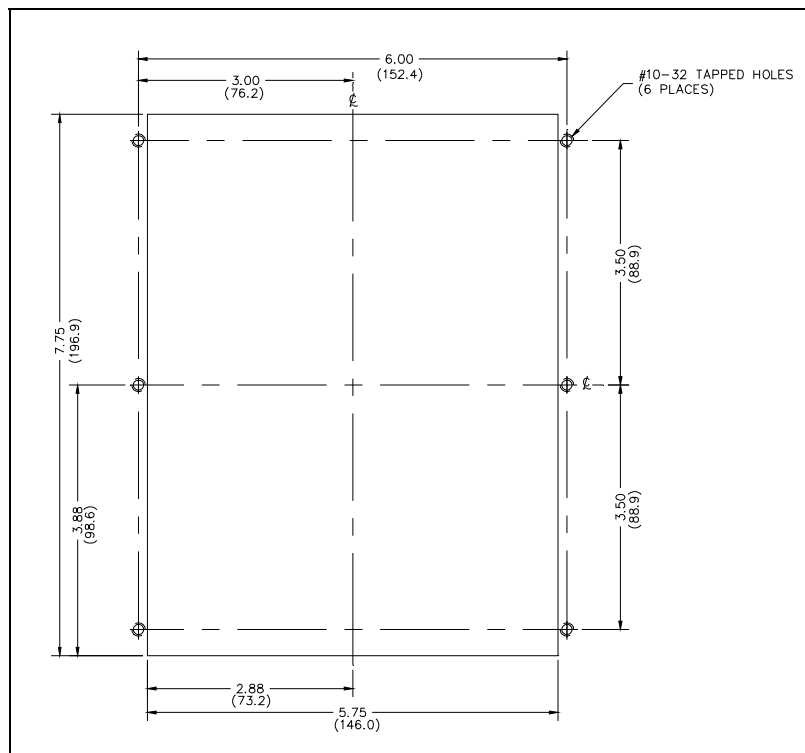

Figure 20. Cutout for Model 397-710FS, 397-711FS, and 398-711FS

## Field Wiring

Pull the required field cables into the rear enclosure and install the connections as indicated below (see [Figure 21](#)).

**NOTE:** Consult the National Electrical Code (NFPA 70), Canadian Standards Association (CSA 22.1), and local codes for the specific requirements regarding your installation. Install all equipment without modification and according to the local and national codes. Class 2 circuit wiring must be performed in accordance with the NEC.

### Recommended Cabling

Table 2. Recommended Cabling

Cable Use	Size and Type
Power	Two-conductor, No. 22 AWG is typical
Inputs	Two-conductor, No. 22 AWG is typical
Output contacts	Two-conductor, No. 18 AWG is typical
Antenna	RG58 coaxial cable

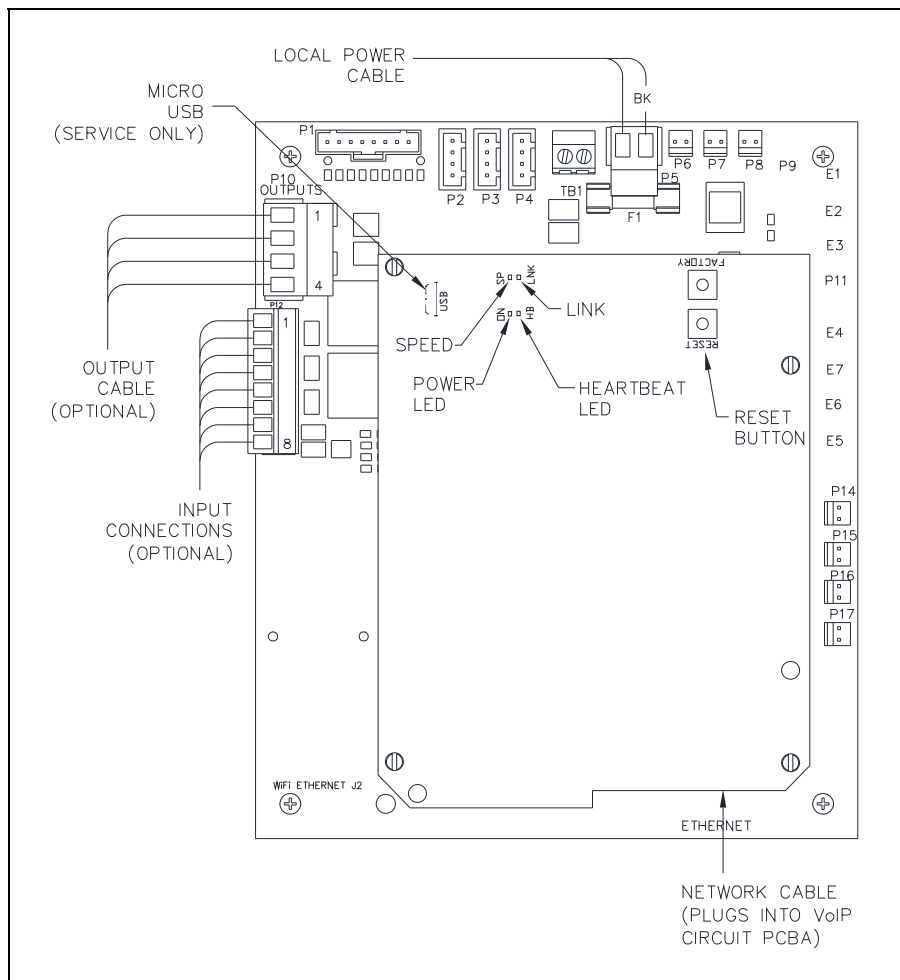

Figure 21. VoIP Telephone PCB Assembly

**Power**

**Ground**

The enclosure must be connected to earth ground.

1. Install a #6 ring lug on the ground conductor.
2. Secure it with the ground terminal located on the rear of the front panel (see [Figure 8](#) and [Figure 13](#)).

**Power-Over-Ethernet (PoE)**

Connect power to the system as indicated in your PoE equipment manual.

**Local Power**

A separate, isolated, 24 to 48-volt dc power supply is required when PoE is not available (see [Table 7](#) on [Page 24](#) for the recommended optional plug-in power supply) (required only if PoE is not available). Connect the local 24–48 V dc power source to removable terminal block, P5. Connect the positive conductor to the (+) terminal and the negative conductor to the (–) terminal of P5 (see [Figure 21](#)).

Table 3. Local Power Connection—P5

<b>Pin</b>	<b>Label</b>	<b>Description</b>
1	(+)	Positive
2	(–)	Negative

**Network**

Connect a category 5 or better UTP cable with an RJ45 connector from the LAN (Local Area Network) to the Ethernet jack located on the VoIP PCBA.

**I/O**

**Inputs**

The telephones have four auxiliary inputs for customer use. Terminate these inputs on terminal block P12 (see [Figure 21](#)).

Table 4. Auxiliary Inputs—P12

<b>Pin</b>	<b>Label</b>	<b>Function</b>
1	IN4	Input 4
2	COM	Common
3	IN3	Input 3
4	COM	Common
5	IN2	Input 2
6	COM	Common
7	IN1	Input 1
8	COM	Common

## Outputs

The telephones have two outputs for customer use. Terminate these outputs on connector P10 (see [Figure 21](#)).

Table 5. Output Contacts—P10

Pin	Label	Description
1	C1	Common Output 1
2	NO1	Normally Open Output 1
3	C2	Common Output 2
4	NO2	Normally Open Output 2

## USB port

The USB port is for GAI-Tronics service personnel only. Make no connection to this port.

# Configuration

## VoIP Telephone Input Contacts

RED ALERT VoIP telephones accept four inputs (see the [Specifications](#) section for the input ratings). Each input's mode is configurable. Configure inputs for one of the following modes: On, Off, or On/Off. The inputs can be configured to update a SYSLOG or generate an SNMP trap when active (see [Figure 21](#) on [Page 18](#)). Refer to the Logic Settings section of GTC Pub. 42004-548 for programming instructions for the inputs (see the [Reference Documentation](#) section).

## VoIP Telephone Output Contacts

Each RED ALERT VoIP telephone contains two voltage-free output contacts (see the [Specifications](#) section for the output ratings). Both outputs are single-pole, single-throw contacts. The mode of each output is configurable. Configure outputs for one of the following modes: On, Off, Ring, Connect, Hook, In Use, Ring Out, Registered, or Emergency. The duration of activation, or on/off times, can also be set in some modes (see [Figure 21](#) on [Page 18](#)). Refer to the Logic Settings section of GTC Pub. 42004-548 for programming instructions for the outputs (see the [Reference Documentation](#) section).

## GAI-Tronics Strobe Connection

Each RED ALERT VoIP hands-free telephone includes two solid state relays. Contact one activates peripheral equipment such as beacons, video cameras, and alarm generators when the HELP push button is pressed. The relay can remain energized for the duration of the emergency call.

An output is normally used to operate a GAI-Tronics Model 540-001 or 541-001 Strobe (sold separately) (see [Figure 22](#) on [Page 21](#)). Refer to or the appropriate installation instructions included with each strobe for additional information.

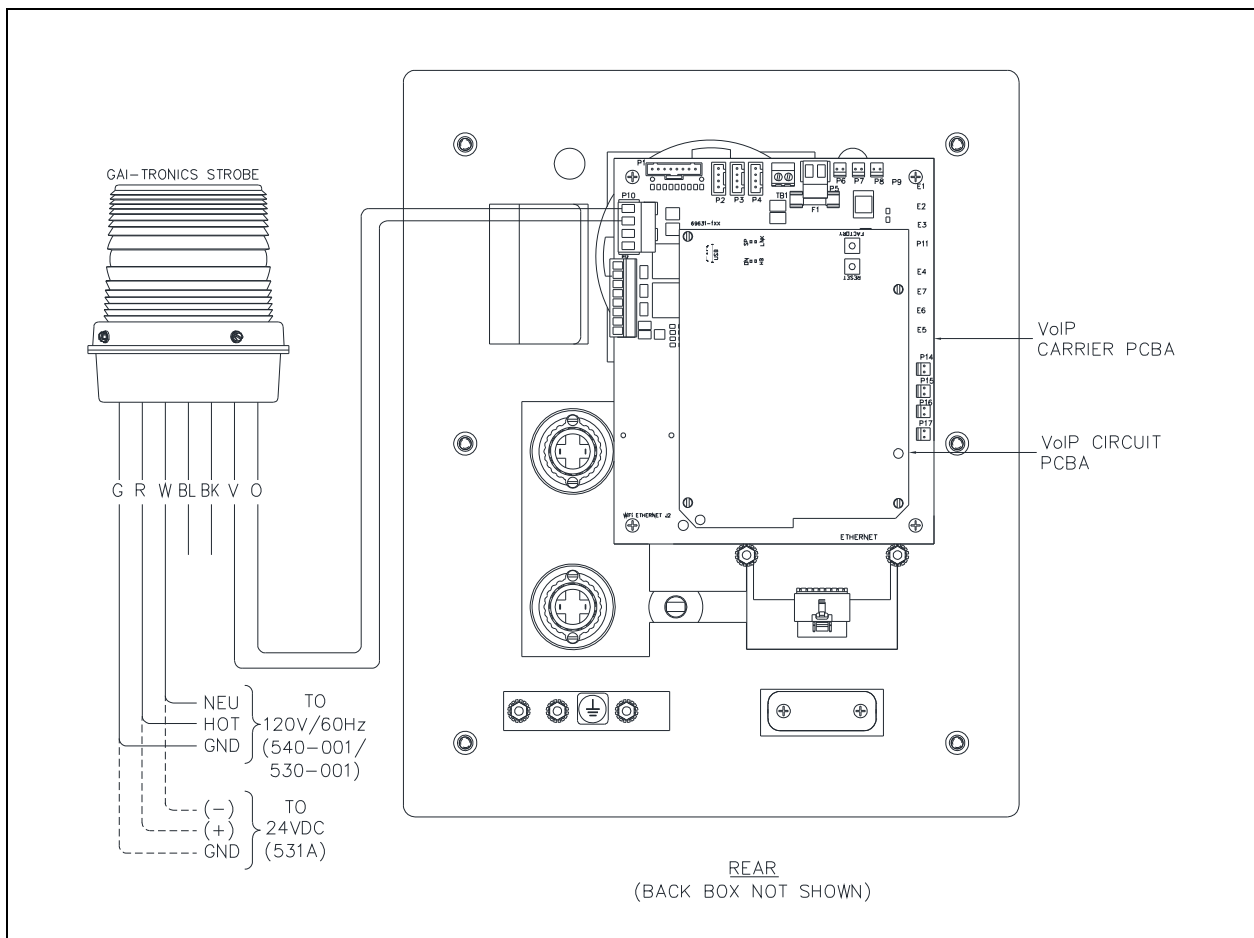

Figure 22. GAI-Tronics Model 540-001 or 541-001 Strobe Connection Detail

## Programming

The installer should ensure that the network is configured to allow VoIP communication (using the SIP protocol) between the desired locations before attempting to configure a GAI-Tronics VoIP telephone.

The general sequence to set up a VoIP Telephone is as follows:

### VoIP PCBA Setup

Verify the PC is connected to the same network as the VoIP telephone.

The easiest way to get started is to make a network connection to the unit and log on via a web browser. The unit is initially set with a static IP address:

IP address: **192.168.1.2**

A username and password are requested. The initial factory settings are:

User Name: **user**

Password: **password**

Changing the username and password is recommended. This security measure helps to prevent unauthorized changes to the VoIP telephone interface's configuration.

## VoIP PCBA Initial Network Configuration

Each VoIP PCBA must be set up for the network prior to installation. Assign a local ID, domain, proxy, and registrar.



Assign a host name      The host name provides identification of the different VoIP PCBAs on the network.

Test                      Verify that calls can be made successfully.

Maintain                Monitor alarms. Set up auto-updates.

Refer to Pub. 42004-548 for basic programming instructions for these VoIP telephones (see the [Reference Documentation](#) section).

## Maintenance

 **WARNING**  —This product can contain hazardous voltages. Always remove power to the station prior to servicing.

### USB port

The USB port is for GAI-Tronics service personnel only. Make no connection to this port.

### Corrective Actions

1. Inspect and replace frayed or cracked wiring.
2. Secure/replace loose wires and terminal lugs.
3. Remove corrosion from terminals.
4. Inspect fuse F1 on the VoIP carrier PCBA.

### Preventive Maintenance for Models 397-71x, 397-71xFS, 398-71x, and 398-711FS

Stainless steel does require maintenance to prevent corrosion from occurring. Different installation locations may require more regular maintenance than others, depending on the environment and exposure to airborne contaminants. The following maintenance steps should be performed on a regular basis or when corrosion is first noticed on a Model 397-71x, 397-71xFS, 398-71x, or 398-711FS telephone.

#### Cleaning

For general cleaning, wipe surface with a cleanser or cleanser and water mixture. Any cleanser that is safe for glass is usually safe for stainless steel. Wipe dry.

If corrosion or rusting is noticed, remove with a non-abrasive commercial cleanser and water. Rub stained areas in the same direction as the existing grain. Stubborn stains may be removed with a paste made from magnesium oxide, ammonia, and water. Wipe clean, rinse with water, and dry.

## Prevention

Automotive wax provides the best results in preventing corrosion on stainless steel. Simply apply wax, let dry to a haze, and buff to a shine with a clean dry cloth. This application should protect the telephone surface for many months as it will allow natural re-formation of the chromium oxide layer.

DO NOT use steel wool, sandpaper, mineral acids, bleaches, or chlorine cleansers on the stainless steel.

## Troubleshooting

Table 6. Troubleshooting

<b>Problem</b>	<b>Possible Solution</b>
low volume	Increase the volume level in the telephone's programming configuration.
high volume	Decrease the volume level in the telephone's programming configuration.
front panel push buttons not operational	Verify the push buttons are properly configured.
inputs not operational	<ul style="list-style-type: none"><li>• Check the input connections.</li><li>• Verify the inputs are properly configured.</li></ul>
outputs not operational	<ul style="list-style-type: none"><li>• Check the output connections.</li><li>• Verify the outputs are properly configured.</li></ul>
cannot make or receive calls	<ul style="list-style-type: none"><li>• Check the connection of the LAN cable.</li><li>• Verify that power is applied to the unit.</li><li>• Verify the LAN parameters have been configured properly.</li><li>• Verify the telephone has been set up on the network.</li></ul>
no power indication	<ul style="list-style-type: none"><li>• Check the power connections.</li><li>• If using PoE, check the operation of the PoE equipment.</li></ul>

## Service

Contact a regional service center for an RA# (return authorization number) if a RED ALERT VoIP telephone requires service. Equipment must be shipped prepaid to GAI-Tronics with an RA# and a purchase order number. Repairs or a replacement will be made in accordance with GAI-Tronics' warranty policy if the equipment is under warranty. Please include a written explanation of all defects to assist our technicians in their troubleshooting efforts.

Call 800-492-1212 inside the USA or 610-777-1374 outside the USA for help with identifying the nearest regional service center.

## Replacement and Optional Parts

Table 7. Replacement and Optional Parts

Part No.	Description	398-712	398-711FS	398-711	397-711FS	397-711	397-710FS	397-710	394AL-712	393AL-710	393-710
233-001	Model 233-001 Security Screwdriver	■	■	■		■					
12565-712	VoIP Carrier PCBA Replacement Kit	■	■								
51035-005A	PCBA, Keypad, metallic	■		■							
51035-019	PCBA, Keypad Assembly with Connector		■								
12542-002	Security Screws (Torx T-25), ½ inch, Pack of 15		■	■							
12516-003	Security Screws (Torx T-25), 1-1/8 inches, Pack of 10								■	■	■
12520-009	Push Button Replacement Kit (Help or Emergency)					■			■	■	
12520-010	Push Button Replacement Kit (Call or Assistance)			■					■		
12520-011 †	Piezo Button, Red (HELP)						■				
12520-012 †	Piezo Button, Black (CALL, ASSISTANCE)										
12521-004	Microphone Replacement Kit						■	■	■	■	■
12522-007	Piezo Speaker Replacement Kit						■	■	■	■	■
21245-003	Terminal Block Connector, 2-Position (External power)						■	■	■	■	■
21245-002	Terminal Block Connector, 4-Position (Outputs)						■	■	■	■	■
62317-208	8-Point Connector (Inputs)						■	■	■	■	■
40419-011	Power Supply, 120/240 V ac—24 v dc, 1 A						■	■	■	■	■



## Reference Documentation

VoIP Telephone Basic Configuration Guide .....	42004-548
VoIP Telephone Firmware Configuration Guide.....	502-20-0171-001

## Specifications

### Electrical

#### Power

Network power.....	Power-over-Ethernet, 802.3af compliant (via RJ45)
Local power requirement .....	24 to 48 V dc, 6 W

#### Network

Cable .....	10/100 BaseT Ethernet RJ45, Category 5 or better UTP
Addressing .....	static IP provisioning or DHCP STUN client (NAT traversal)
Call control signaling.....	SIP (RFC3261 compliant) loose routing
Configuration .....	embedded web server, configuration file download, direct serial connection, and password protection

#### Inputs

Keypad (Model 394AL-712 only) .....	3 × 4 matrix
Push buttons.....	three autodial and an off-hook indicator/switch
Configurable inputs (quantity = 4).....	internal pull-up 3.3 V dc tolerant

#### Outputs

Output 1 .....	8 A @ 30 V ac/dc (resistive load)
Output 2 .....	8 A @ 30 V ac/dc (resistive load)

#### Indicators

External.....	off-hook indicator light
Internal on VoIP PCBA .....	power, heartbeat, speed, and link LEDs
Audio output .....	85 dB SPL or greater @ 1.0 m (@ 1 kHz)

### Mechanical

#### Temperature range:

Operating.....	-4 °F to +131 °F (-20 °C to +55 °C)
Storage.....	-40 °F to +158 °F (-40 °C to +70 °C)
Relative humidity.....	up to 95%, non-condensing
PCBA (printed circuit board assembly) .....	conformal coated

#### Model 393-710

Enclosure construction.....	engineered plastic, safety yellow
Dimensions .....	9.50 H × 8.00 W × 4.00 D in (241.3 × 203.2 × 101.6 mm)
Weight.....	4.0 lb (1.8 kg)

#### Models 393AL-710 and 394AL-712

#### Construction:

Enclosure .....	cast aluminum painted safety yellow
Braille keypad (Model 394AL-712 only).....	chrome-plated zinc
Dimensions .....	9.50 H × 8.00 W × 4.00 D in (241.3 × 203.2 × 101.6 mm)

Weight:

Model 393AL-710.....	7.8 lb (3.5 kg)
Model 394AL-712.....	8.5 lb (3.8 kg)

**Models 397-710, 397-711, 398-711 and 398-712**

Construction:

Panel.....	14-gauge, type 304 brushed stainless steel
Back box.....	16-gauge cold-rolled steel with black polyurethane finish
Braille keypad (Model 398-712 only).....	chrome-plated zinc

Dimensions:

Front panel.....	12.00 H × 10.00 W in (304.8 × 254.0 mm)
Back box (overall).....	10.06 H × 8.43 W × 2.50 D in (255.5 × 214.1 × 63.5 mm)
Cutout for mounting back box.....	10.13 H × 7.63 W in (257.3 × 193.8 mm)

Weight:

Model 397-710.....	6.5 lb (2.9 kg)
Model 397-711.....	6.5 lb (2.9 kg)
Model 398-711.....	7.2 lb (3.3 kg)
Model 398-712.....	7.2 lb (3.3 kg)

**Models 397-710FS, 397-711FS, and 398-711FS**

Construction:

Panel.....	14-gauge, type 304 brushed stainless steel
Back box.....	16-gauge cold-rolled steel with black polyurethane finish
Keypad (Model 398-711FS only).....	chrome-plated zinc

Dimensions:

Front panel.....	8.5 H × 6.5 W in (215 × 165.1 mm)
Back box (overall).....	7.62 H × 5.62 W × 2.37 D in (193.6 × 142.7 × 60.2 mm)
Cutout for flush mounting.....	7.75 H × 5.75 W in (196.9 × 146.1 mm)

Weight.....	5 lb (2.3 kg)
-------------	---------------

## Approvals

Compliance to Standard.....	FCC CFR 47 Part 15
Safety of Information Technology Equipment.....	UL/CSA 60950
Enclosure for Electrical Equipment.....	Type 3R

**NOTE:** This equipment has been tested and found to comply with the limits for a Class A digital device, pursuant to part 15 of the FCC Rules. These limits are designed to provide reasonable protection against harmful interference when the equipment is operated in a commercial environment. This equipment generates, uses, and can radiate radio frequency energy and, if not installed and used in accordance with the instruction manual, may cause harmful interference to radio communications. Depending upon the wiring and features used on this device, additional precautions may be necessary not to cause harmful interference. Operation of this equipment in a residential area is likely to cause harmful interference in which case the user will be required to correct the interference at his own expense.

# Warranty

---

Equipment. GAI-Tronics warrants for a period of one (1) year from the date of shipment, that any GAI-Tronics equipment supplied hereunder shall be free of defects in material and workmanship, shall comply with the then-current product specifications and product literature, and if applicable, shall be fit for the purpose specified in the agreed upon quotation or proposal document. If (a) Seller's goods prove to be defective in workmanship and/or material under normal and proper usage, or unfit for the purpose specified and agreed upon, and (b) Buyer's claim is made within the warranty period set forth above, Buyer may return such goods to GAI-Tronics nearest depot repair facility, freight prepaid, at which time they will be repaired or replaced, at Seller's option, without charge to Buyer. Repair or replacement shall be Buyer's sole and exclusive remedy. The warranty period on any repaired or replacement equipment shall be the greater of the ninety (90) day repair warranty or one (1) year from the date the original equipment was shipped. In no event shall GAI-Tronics warranty obligations with respect to equipment exceed 100% of the total cost of the equipment supplied hereunder. Buyer may also be entitled to the manufacturer's warranty on any third-party goods supplied by GAI-Tronics hereunder. The applicability of any such third-party warranty will be determined by GAI-Tronics.

Services. Any services GAI-Tronics provides hereunder, whether directly or through subcontractors, shall be performed in accordance with the standard of care with which such services are normally provided in the industry. If the services fail to meet the applicable industry standard, GAI-Tronics will re-perform such services at no cost to buyer to correct said deficiency to Company's satisfaction provided any and all issues are identified prior to the demobilization of the Contractor's personnel from the work site. Re-performance of services shall be Buyer's sole and exclusive remedy, and in no event shall GAI-Tronics warranty obligations with respect to services exceed 100% of the total cost of the services provided hereunder.

Warranty Periods. Every claim by Buyer alleging a defect in the goods and/or services provided hereunder shall be deemed waived unless such claim is made in writing within the applicable warranty periods as set forth above. Provided, however, that if the defect complained of is latent and not discoverable within the above warranty periods, every claim arising on account of such latent defect shall be deemed waived unless it is made in writing within a reasonable time after such latent defect is or should have been discovered by Buyer.

Limitations / Exclusions. The warranties herein shall not apply to, and GAI-Tronics shall not be responsible for, any damage to the goods or failure of the services supplied hereunder, to the extent caused by Buyer's neglect, failure to follow operational and maintenance procedures provided with the equipment, or the use of technicians not specifically authorized by GAI-Tronics to maintain or service the equipment. **THE WARRANTIES AND REMEDIES CONTAINED HEREIN ARE IN LIEU OF AND EXCLUDE ALL OTHER WARRANTIES AND REMEDIES, WHETHER EXPRESS OR IMPLIED BY OPERATION OF LAW OR OTHERWISE, INCLUDING ANY WARRANTIES OF MERCHANTABILITY OR FITNESS FOR A PARTICULAR PURPOSE.**

## Return Policy

---

If the equipment requires service, contact your Regional Service Center for a return authorization number (RA#). Equipment should be shipped prepaid to GAI-Tronics with a return authorization number and a purchase order number. If the equipment is under warranty, repairs or a replacement will be made in accordance with the warranty policy set forth above. Please include a written explanation of all defects to assist our technicians in their troubleshooting efforts.

Call 800-492-1212 (inside the USA) or 610-777-1374 (outside the USA) for help identifying the Regional Service Center closest to you.